

- 32-Channel Input
- Dual Programmable Voltage Threshold, 0.3 to 50 V
- High Input Voltage Tolerance
- 32-Channel Output
- High Side or Low Side Driving
- 0.5 A Low Side Sink Capability
- 0.4 A High Side Source Capability
- Fully Protected Outputs
- High Side External Voltage Input
- VISA, IVI & Kernel Drivers Supplied for Windows
- 3 Year Warranty



The 50-412 is a 32-channel Digital I/O card with high output voltage and current capability and dual variable threshold inputs.

The outputs can be used as high side drivers capable of sourcing 0.4 A or low side drivers capable of sinking 0.5 A. Accidental operation of both the high and low side driver is prevented by the supplied software. The outputs are fully protected against over-voltage, over-current and thermal overload, ensuring robust and reliable operation in the toughest test environments. For high side driving, voltage is supplied from an external source, allowing the card to drive high capacity loads without impacting the backplane power supply. For low side driving the external source can be left unconnected, allowing the card to be used for applications requiring open collector or open drain drivers.

The built in protection systems allow the card to drive relays without flyback diodes as an overvoltage clamp is included.

The 32 inputs are read through the PCI interface by comparing the signal levels to two threshold voltages. These can be set between 0.3V and 50 V with 12.5 mV resolution. Series acquisition is used to capture the input status using a single set of comparators. The driver includes a facility to capture the input status of all 32 channels from a single command.

The inputs can withstand the accidental application of more than 100 V. Inputs can be connected to outputs without risk of damage, allowing the card to be configured for operation as 32 channels of independent input and output or as 32 channels of configurable I/O.

The 50-412 uses a 78-pin D-type connector which is supported by a full range of connector accessories.

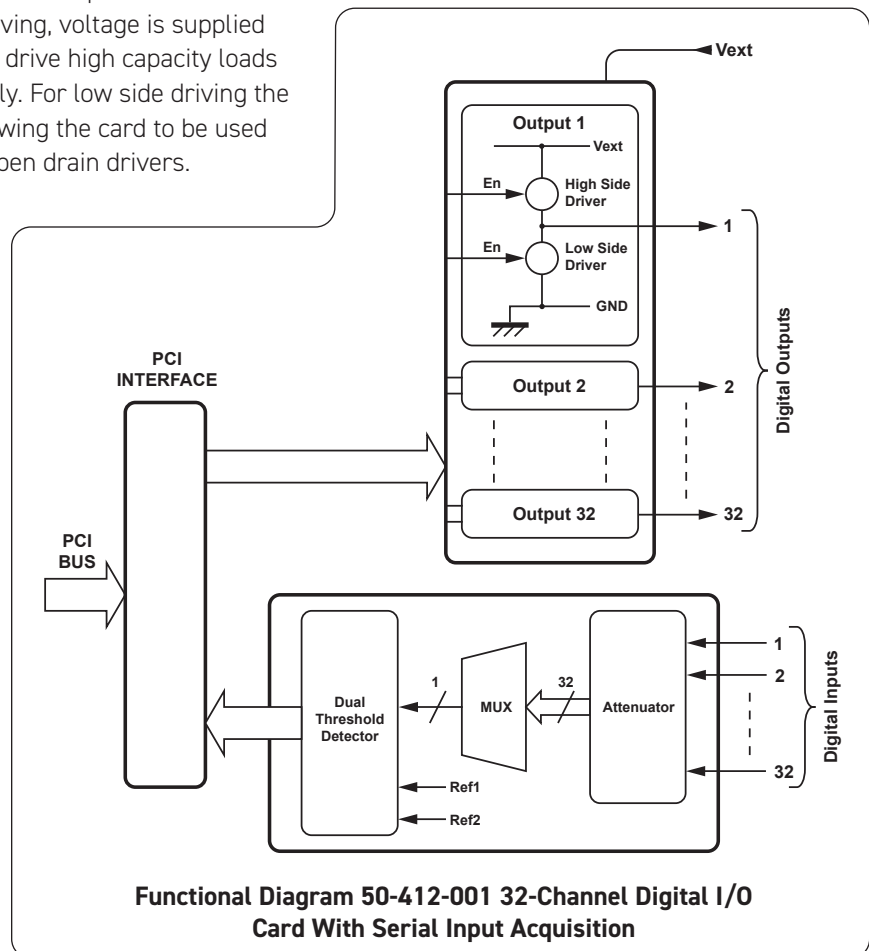

**Functional Diagram 50-412-001 32-Channel Digital I/O Card With Serial Input Acquisition**

## Output Specification

No. of Output Channels:	32
Output States:	Driven high, driven low or off.
Low Side Driver Output Resistance:	0.6 $\Omega$ at 0.5 A
High Side Driver Output Voltage:	Vext less 1.5 V at 0.4 A
Maximum Current:	0.5 A for Low Side drivers, 0.4 A for High Side drivers, 8 A module total. Note: for full load conditions, adequate cooling is assumed.
Maximum Voltage:	+50 V*
Output Protection:	Current limited, overvoltage limited, thermal protection. Overvoltage limit can be used to limit back emf generated from inductive loads such as relay coils.
Vext:	User supplied +5 V to +50 V, applied to multiple pins of user connector, relative to front panel ground.

\* For full voltage rating, signal sources must be fully isolated from mains supply and safety earth.

## Input Specification

No. of Input Channels:	32
Logic Threshold:	Compares selected input voltage against two reference voltages, each of which can be set from 0.3 V to 50 V with 12.5 mV setting resolution.
Settling Time:	50 $\mu$ s following a state change or channel selection. Typical read back time for all 32 states 1.3 ms.
Channel Selection:	Single channel selection or automated sequential access to all 32 channels.
Maximum Input Voltage:	100 V*
Input Impedance:	1 M $\Omega$

\* For full voltage rating, signal sources must be fully isolated from mains supply and safety earth.

## Power Requirements

+3.3V	+5V	+12V	-12V
200 mA	50 mA	0 A	50 mA

## Mechanical Characteristics

Single slot short PCI format.

Card weight: 130 g.

3D models for all versions in a variety of popular file formats are available on request.

## Connectors

Signals via a 78-pin male D-type connector, for pin outs please refer to the operating manual.

## PXI & CompactPCI Compliance

The 50-412 card complies with the PCI Specification 2.0 (issued Feb 2004).

Signalling Environment: 33 MHz, 32-bit Universal (+3.3 V & +5 V).

## Safety & CE Compliance

All cards are fully CE compliant and meet applicable EU directives: Low-voltage safety EN61010-1:2010, EMC Immunity EN61326-1:2013, Emissions EN55011:2009+A1:2010.

## Operating/Storage Conditions

### Operating Conditions

Operating Temperature: 0°C to +55°C  
Humidity: Up to 90% non-condensing  
Altitude: 5000 m

### Storage and Transport Conditions

Storage Temperature: -20°C to +75°C  
Humidity: Up to 90% non-condensing  
Altitude: 15000 m

## Product Order Codes

---

<b>32-Channel Digital I/O Card - Serial Input Acquisition, Programmable Threshold</b>	<b>50-412-001</b>
---	-------------------

---

## Product Customization

Pickering PCI cards are designed and manufactured on our own flexible manufacturing lines, giving complete product control and enabling simple customization to meet very specific requirements.

All customized products are given a unique part number, fully documented and may be ordered at any time in the future. Please contact your local sales office to discuss.

## Mating Connectors & Cabling

---

For connection accessories for the 50-412 card please refer to the [90-006D](#) 78-pin D-type Connector Accessories data sheet where a complete list and documentation can be found for accessories, or refer to the Connection Solutions catalog.

---

## Connectivity Solutions

We provide a full range of supporting cable and connector solutions for all our switching products—20 connector families with 1200+ products. We offer everything from simple mating connectors to complex cables assemblies and terminal blocks. All assemblies are manufactured by Pickering and are guaranteed to mechanically and electrically mate to our modules.



Connectors & Backshells



Multiway Cable Assemblies



RF Cable Assemblies



Connector Blocks

We also offer customized cabling and have a free online **Cable Design Tool** that can be used to create custom cable solutions for many applications. Visit: [pickeringtest.com/cdt](http://pickeringtest.com/cdt) to start your design.

## Mass Interconnect

We recommend the use of a mass interconnect solution when an Interchangeable Test Adapter (ITA) is required for a PXI or LXI based test system. Our modules are fully supported by both Virginia Panel and MacPanel.



## Pickering Reed Relays

We are the only switch provider with in-house reed relay manufacturing capability via our Relay Division. These instrument grade reed relays feature **SoftCenter™** technology, ensuring long service life and repeatable contact performance. To learn more, please go to: [pickeringrelay.com](http://pickeringrelay.com)



## Programming

Pickering provide kernel, IVI and VISA (NI & Keysight) drivers which are compatible with all Microsoft supported versions of Windows and popular older versions. For a list of all supporting operating systems, please see: [pickeringtest.com/os](http://pickeringtest.com/os)

The VISA driver is also compatible with Real-Time Operating Systems such as LabVIEW RT. For other RTOS support contact Pickering. These drivers may be used with a variety of programming environments and applications including:

- **Pickering Interfaces Switch Path Manager**
- **National Instruments** products (LabVIEW, LabWindows/CVI, Switch Executive, MAX, TestStand, VeriStand, etc.)
- **Microsoft Visual Studio** products (Visual Basic, Visual C+)
- **Keysight** VEE and OpenTAP
- **Mathworks** Matlab
- **Marvin** ATEasy
- **MTQ Testsolutions** Tecap Test & Measurement Suite

Drivers for popular Linux distributions are available, other environments are also supported, please contact Pickering with specific enquiries. We provide Soft Front Panels (SFPs) for our products for familiarity and manual control, as well as comprehensive documentation and example programs to help you develop test routines with ease.

To learn more about software drivers and development environments, please go to: [pickeringtest.com/software](http://pickeringtest.com/software)

## Signal Routing Software

Our signal routing software, Switch Path Manager, automatically selects and energizes switch paths through Pickering switching systems. Signal routing is performed by simply defining test system endpoints to be connected together, greatly accelerating Test System software development. To learn more, please go to: [pickeringtest.com/spm](http://pickeringtest.com/spm)

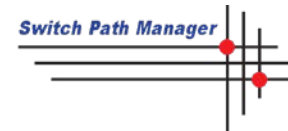

## Diagnostic Relay Test Tools

**eBIRST** Switching System Test Tools are designed specifically for our PXI, PCI or LXI products, these tools simplify switching system fault-finding by quickly testing the system and graphically identifying the faulty relay. To learn more, please go to: [pickeringtest.com/ebirst](http://pickeringtest.com/ebirst)



## Three Year Warranty & Guaranteed Long-Term Support

All standard products manufactured by Pickering Interfaces are warranted against defective materials and workmanship for a period of three years from the date of delivery to the original purchaser. Extended warranty and service agreements are available for all our modules and systems with various levels to suit your requirements. Although we offer a 3-year warranty as standard, we also include guaranteed long-term support—with a history of supporting our products for typically 15-20 years. To learn more, please go to: [pickeringtest.com/support](http://pickeringtest.com/support)

## Available Product Resources

We have a large library of product resources including success stories, product and support videos, articles and white papers as well as application specific product brochures to assist when looking for the switching, simulation and connection solutions you need. We have also published handy reference books on Switching Technology and for the PXI and LXI standards.



To view, download or request any of our product resources, please visit: [pickeringtest.com/resources](http://pickeringtest.com/resources)

© Copyright (2021) Pickering Interfaces. All Rights Reserved. Pickering Interfaces maintains a commitment to continuous product development, consequently we reserve the right to vary from the description given in this data sheet.